

Pilote ID

France National_2 connu

Vol N°

No	Symbol	Cat. No.	K	Total K	Marks	Remarks	Pos	Item	K	Grade
1		1.1.7.1 9.1.1.1	9 6	15				Pos.	20	
2		1.1.7.4 9.12.1.5	9 6	15				Fig K		Total K
3		5.2.1.3 9.4.1.2	18 9	27				224		244
4		7.2.2.2 9.1.3.2	9 4	13				Penalties		
5		2.2.4.4	17	17				Trop Bas		
6		8.5.6.1 9.1.3.8 9.8.4.2	10 12 7	29				Trop Haut		
7		8.4.3.1 9.1.5.1	15 2	17				Interruptions		
8		8.6.1.1 9.8.1.1 9.8.3.1 9.1.3.1	11 7 3 2	23				Insertions		
9		8.5.2.1 9.9.2.2	10 13	23				Echaf. non OK		
10		7.2.2.1 9.1.3.4 9.4.3.2	6 8 5	19				Battem. d'Ailes		
11		2.3.1.1	5	5				Disqualifié		
12		1.1.1.1 9.9.3.4 9.1.3.4	2 11 8	21				Autre(noter...)		
								Final Freestyle		
								Duration	Min	Sec
								Judges Details		
								Signature		
								Name		
								Number		

Le K Aresti normal de la figure 5 a été changé selon le règlement 2017 france national_2 connu

Pilote
Avion

Pilote ID

France National_2 connu

Vol N°

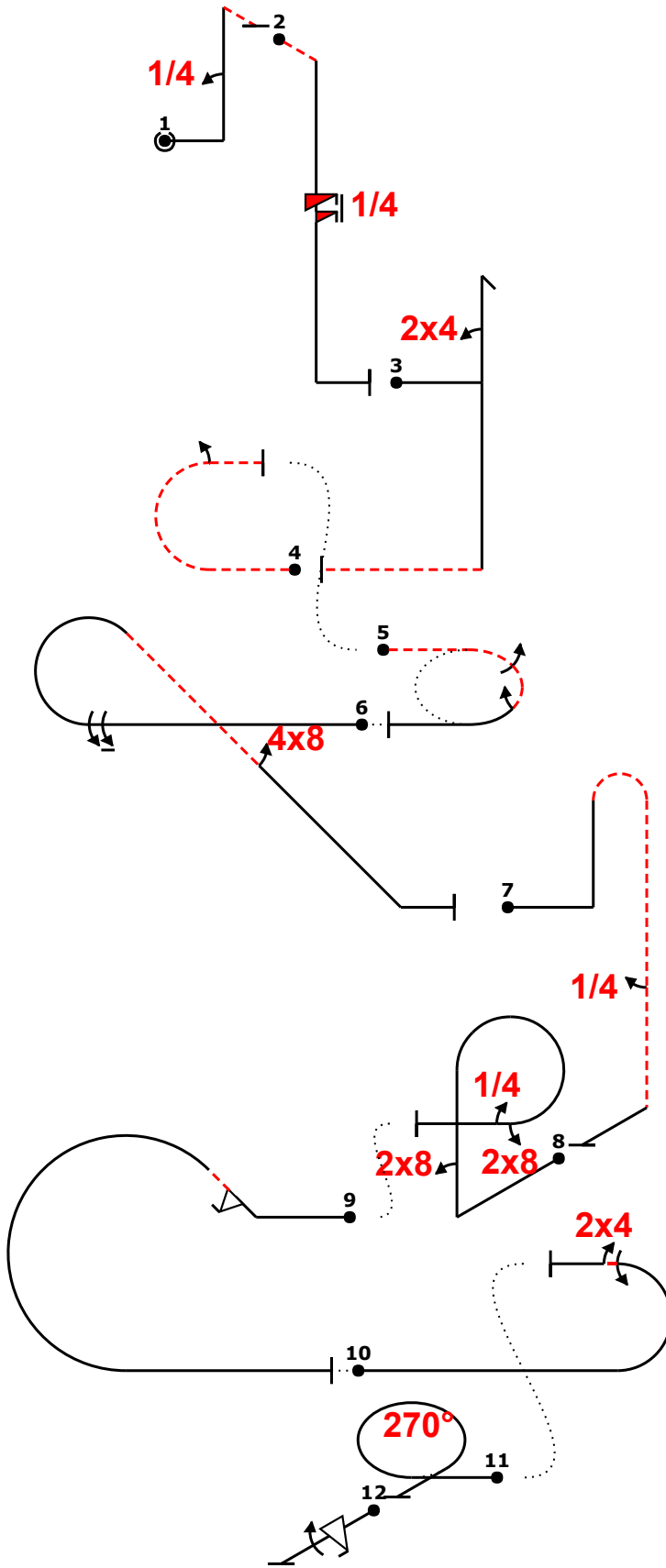

Avion			
Fig 1	1.1.7.1 9.1.1.1	9 6	15
Fig 2	1.1.7.4 9.12.1.5	9 6	15
Fig 3	5.2.1.3 9.4.1.2	18 9	27
Fig 4	7.2.2.2 9.1.3.2	9 4	13
Fig 5	2.2.4.4	17	17
Fig 6	8.5.6.1 9.1.3.8 9.8.4.2	10 12 7	29
Fig 7	8.4.3.1 9.1.5.1	15 2	17
Fig 8	8.6.1.1 9.8.1.1 9.8.3.1 9.1.3.1	11 7 3 2	23
Fig 9	8.5.2.1 9.9.2.2	10 13	23
Fig 10	7.2.2.1 9.1.3.4 9.4.3.2	6 8 5	19
Fig 11	2.3.1.1	5	5
Fig 12	1.1.1.1 9.9.3.4 9.1.3.4	2 11 8	21
Total K = 224 (max K = 225)			

Le K Aresti normal de la figure 5 a été changé selon le règlement 2017 france national_2 connu

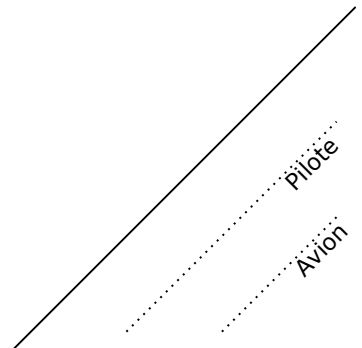

Pilote ID

France National_2 connu

Vol N°

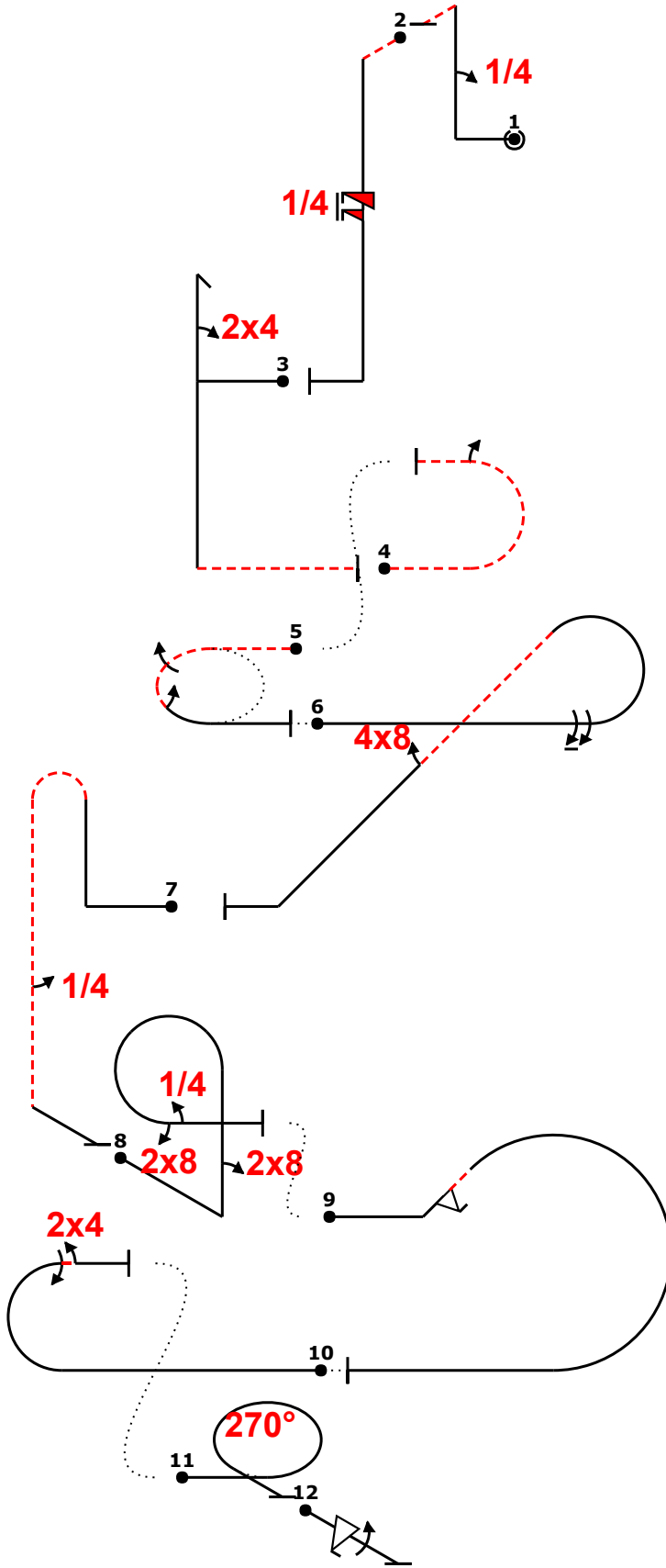

Avion			
Fig 1	1.1.7.1 9.1.1.1	9 6	15
Fig 2	1.1.7.4 9.12.1.5	9 6	15
Fig 3	5.2.1.3 9.4.1.2	18 9	27
Fig 4	7.2.2.2 9.1.3.2	9 4	13
Fig 5	2.2.4.4	17	17
Fig 6	8.5.6.1 9.1.3.8 9.8.4.2	10 12 7	29
Fig 7	8.4.3.1 9.1.5.1	15 2	17
Fig 8	8.6.1.1 9.8.1.1 9.8.3.1 9.1.3.1	11 7 3 2	23
Fig 9	8.5.2.1 9.9.2.2	10 13	23
Fig 10	7.2.2.1 9.1.3.4 9.4.3.2	6 8 5	19
Fig 11	2.3.1.1	5	5
Fig 12	1.1.1.1 9.9.3.4 9.1.3.4	2 11 8	21
Total K = 224 (max K = 225)			

Le K Aresti normal de la figure 5 a été changé selon le règlement 2017 france national_2 connu

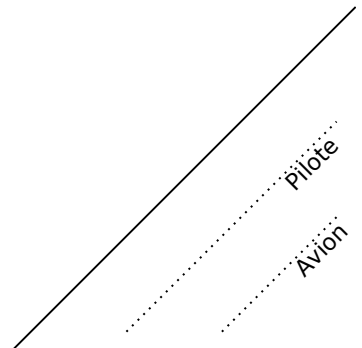



Figure K
224
K total
244

Nom des Juges		Vol N°
Signature	Numéro	

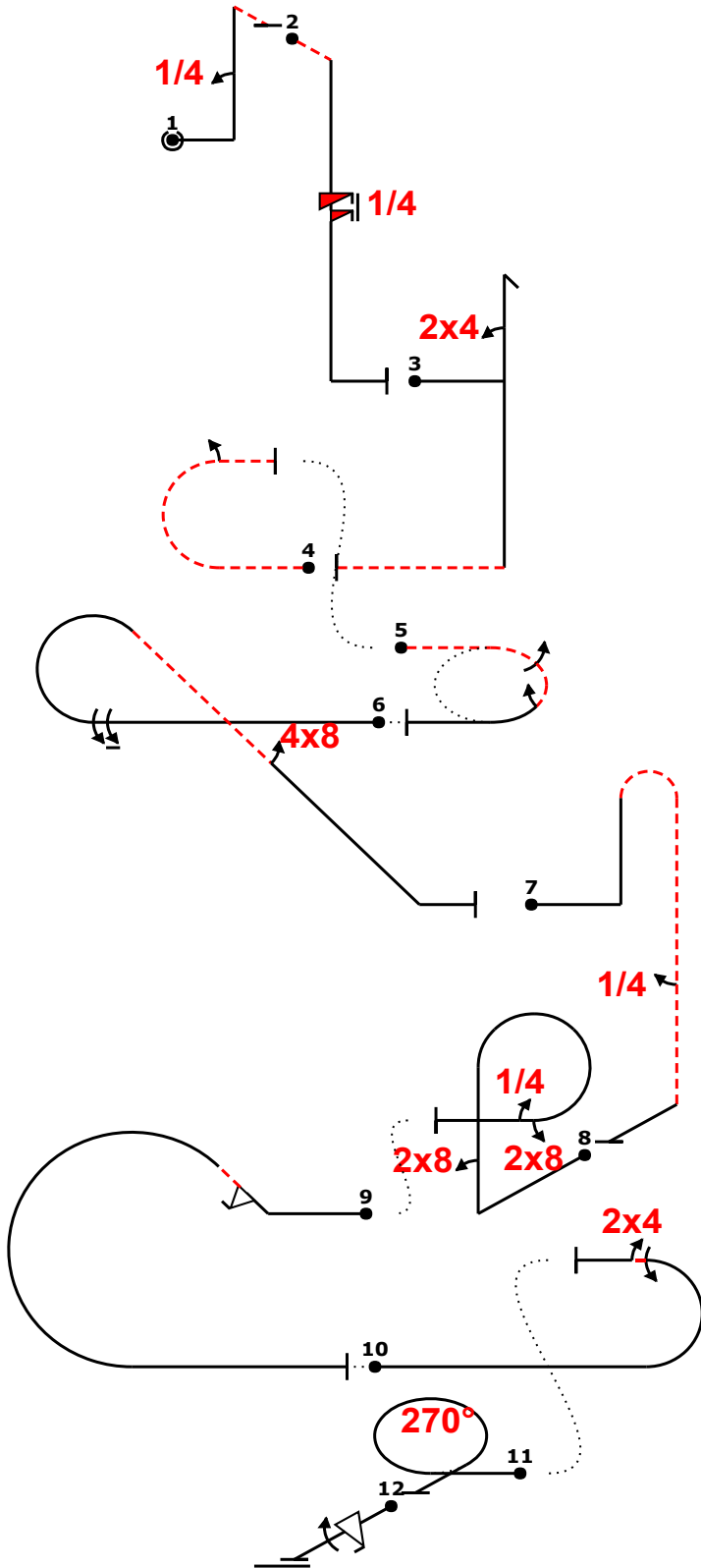

Fig	Pos	Remarks	Grade
1			.
2			.
3			.
4			.
5			.
6			.
7			.
8			.
9			.
10			.
11			.
12			.

Cadre(Coef)	20	.
-------------	----	---

Trop Bas		Echauf. non OK	
Trop Haut		Battem. d'Ailes	
Interruptions		Disqualifié	
Insertions		Autre(noter...)	

Le K Aresti normal de la figure 5 a été changé selon le règlement 2017 france national_2 connu
 Vérification :11-12-2017 11:04 OpenAero 2018.1.1 2017 france national_2 connu Le programme est correct
 /v'4'- -iv..5is...> ~24h...~m2- (5,14) -2joi15 (2,0) .''9c...''48.. 2> /pb...''4.'''~w ~++''8'rp8,
 4 (-1,7) 12% '+' ~2f''rc+ (-2,0)m1,24 (0,16) 3j f,1

Fig 1	K	Fig 2	K	Fig 3	K	Fig 4	K	Fig 5	K	Fig 6	K	Fig 7	K	Fig 8	K	Fig 9	K	Fig 10	K	Fig 11	K	Fig 12	K
1.1.7.1	9	1.1.7.4	9	5.2.1.3	18	7.2.2.2	9	2.2.4.4	17	8.5.6.1	10	8.4.3.1	15	8.6.1.1	11	8.5.2.1	10	7.2.2.1	6	2.3.1.1	5	1.1.1.1	2
9.1.1.1	6	9.12.1.5	6	9.4.1.2	9	9.1.3.2	4			9.1.3.8	12	9.1.5.1	2	9.8.1.1	7	9.9.2.2	13	9.1.3.4	8			9.9.3.4	11
										9.8.4.2	7			9.8.3.1	3			9.4.3.2	5			9.1.3.4	8
														9.1.3.1	2								
SF 7	15	SF 3	15	SF 5	27	SF 7	13	SF 2	17	SF 7	29	SF 7	17	SF 7	23	SF 4	23	SF 7	19	SF 2	5	SF 4	21

Pilote:

Avion:

Equipe: FRA

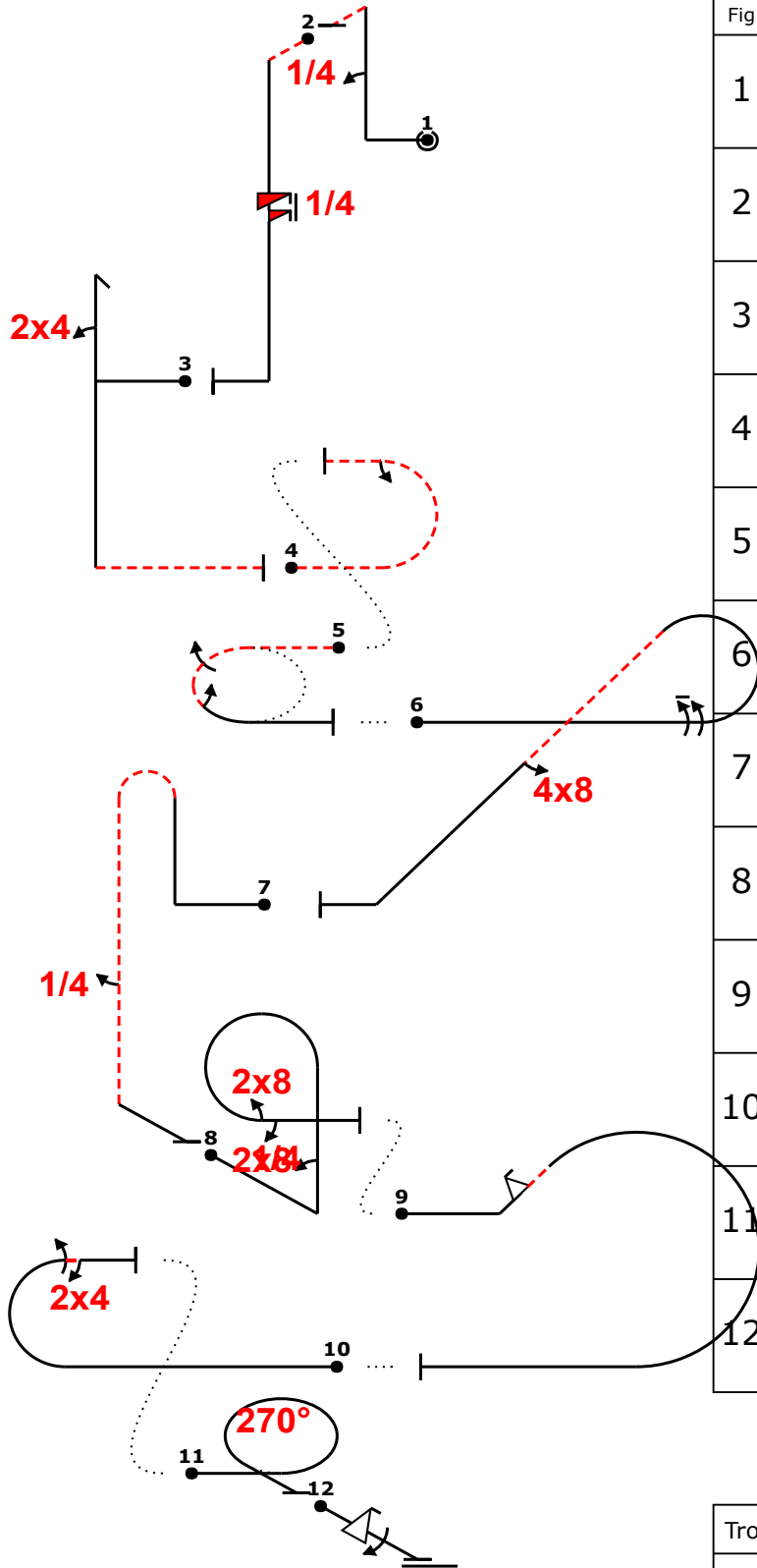

Fig	Pos	Remarks	Grade
1			.
2			.
3			.
4			.
5			.
6			.
7			.
8			.
9			.
10			.
11			.
12			.

Cadre(Coef)	20	.
-------------	----	---

Trop Bas		Echauf. non OK	
Trop Haut		Battem. d'Ailes	
Interruptions		Disqualifié	
Insertions		Autre(noter...)	





Le K Aresti normal de la figure 5 a été changé selon le règlement 2017 france national_2 connu
 Vérification :11-12-2017 11:04 OpenAero 2018.1.1 2017 france national_2 connu Le programme est correct
 /v'4'- -iv..5is...> ~24h...m2- (5,14) -2joi15 (2,0) .''9c...''48.. 2> /pb...',4.'''~++''8'rp8,
 4 (-1,7) 12% '+' ~2f''rc+ (-2,0)m1,24 (0,16) 3j f,1

Fig 1	K	Fig 2	K	Fig 3	K	Fig 4	K	Fig 5	K	Fig 6	K	Fig 7	K	Fig 8	K	Fig 9	K	Fig 10	K	Fig 11	K	Fig 12	K
1.1.7.1	9	1.1.7.4	9	5.2.1.3	18	7.2.2.2	9	2.2.4.4	17	8.5.6.1	10	8.4.3.1	15	8.6.1.1	11	8.5.2.1	10	7.2.2.1	6	2.3.1.1	5	1.1.1.1	2
9.1.1.1	6	9.12.1.5	6	9.4.1.2	9	9.1.3.2	4			9.1.3.8	12	9.1.5.1	2	9.8.1.1	7	9.9.2.2	13	9.1.3.4	8			9.9.3.4	11
										9.8.4.2	7			9.8.3.1	3			9.4.3.2	5			9.1.3.4	8
										9.1.3.1	2												
SF 7	15	SF 3	15	SF 5	27	SF 7	13	SF 2	17	SF 7	29	SF 7	17	SF 7	23	SF 4	23	SF 7	19	SF 2	5	SF 4	21

Pilote ID

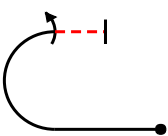
France National_2 connu

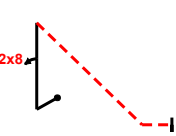
Vol N°

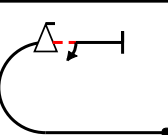
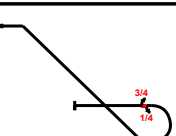
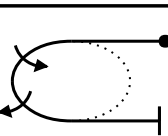
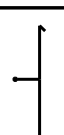
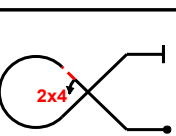
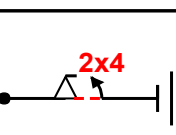
No	Symbol	Cat. No.	K	Total K	Marks	Remarks	Pos	Item	K	Grade
1		5.3.2.1 9.4.2.2 9.1.5.2	24 7 4	35				Pos.	20	
2		7.2.1.1 9.1.3.4	6 8	14				Fig K		Total K
								225		245
3		1.1.7.4 9.12.1.5	9 6	15				Penalties		
								Trop Bas		
								Trop Haut		
4		1.2.5.1 9.8.1.1	14 7	21				Interruptions		
								Insertions		
								Echaf. non OK		
5		5.2.1.4 9.1.1.1 9.1.5.1	22 6 2	30				Battem. d'Ailes		
								Disqualifié		
								Autre(noter...)		
6		7.2.2.1 9.9.3.4 9.1.3.2	6 11 4	21				Final Freestyle		
								Duration	Min	Sec
7		8.5.3.3 9.1.3.1 9.1.3.3	10 2 6	18				Judges Details		
								Signature		
								Name		
								Number		
8		2.2.6.1	15	15						
9		5.2.1.1	17	17						
10		7.3.2.1 9.4.2.2	14 7	21						
11		1.1.1.1 9.9.3.2 9.4.3.2	2 11 5	18						

Le K Aresti normal de la figure 8 a été changé selon le règlement 2017 france national_2 connu

Pilote
Avion

CONNU N°2 2018		Form B
Pilote ID	France National_2 connu	Vol N°

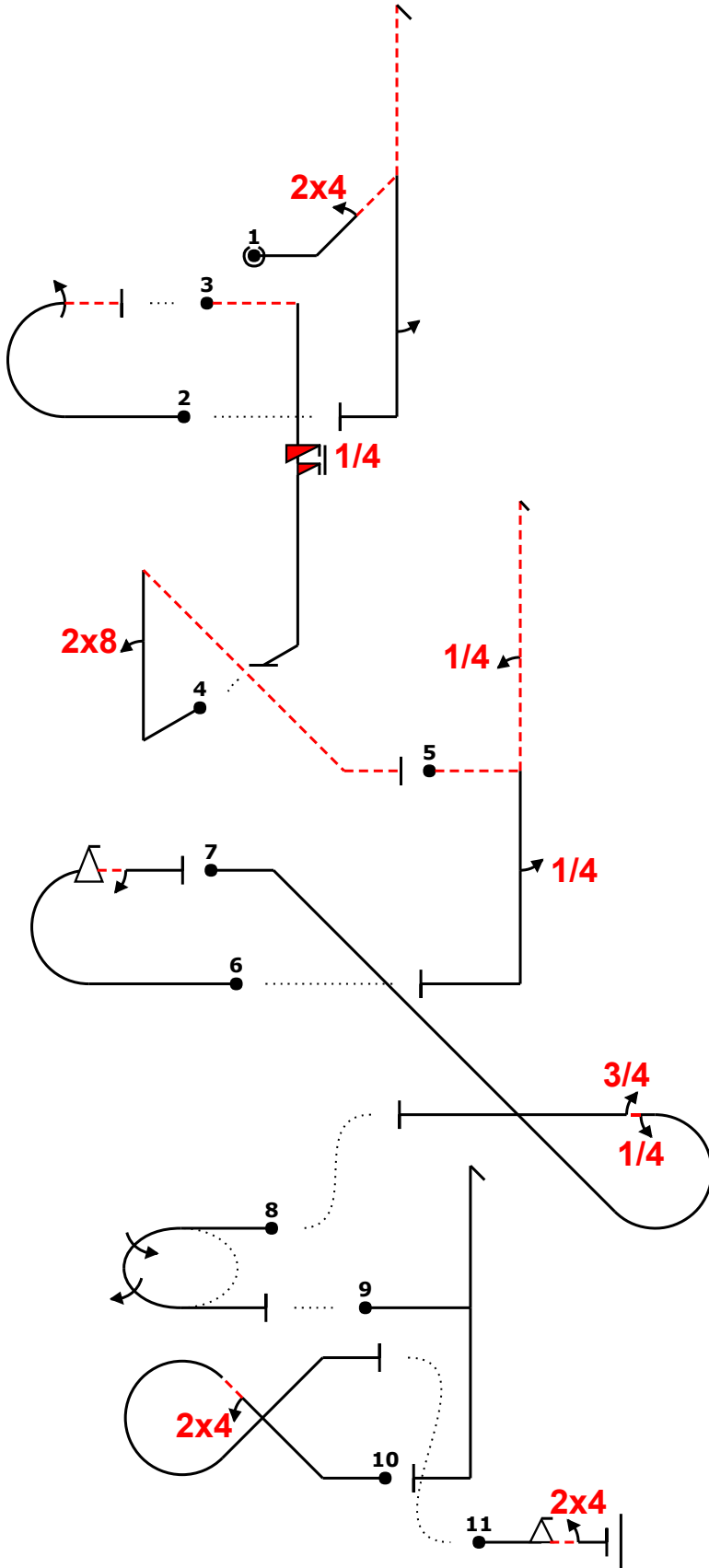

Avion			
Fig 1	5.3.2.1 9.4.2.2 9.1.5.2	24 7 4	35
Fig 2	7.2.1.1 9.1.3.4	6 8	14
Fig 3	1.1.7.4 9.12.1.5	9 6	15
Fig 4	1.2.5.1 9.8.1.1	14 7	21
Fig 5	5.2.1.4 9.1.1.1 9.1.5.1	22 6 2	30
Fig 6	7.2.2.1 9.9.3.4 9.1.3.2	6 11 4	21
Fig 7	8.5.3.3 9.1.3.1 9.1.3.3	10 2 6	18
Fig 8	2.2.6.1	15	15
Fig 9	5.2.1.1	17	17
Fig 10	7.3.2.1 9.4.2.2	14 7	21
Fig 11	1.1.1.1 9.9.3.2 9.4.3.2	2 11 5	18
Total K = 225 (max K = 225)			

Le K Aresti normal de la figure 8 a été changé selon le règlement 2017 france national_2 connu

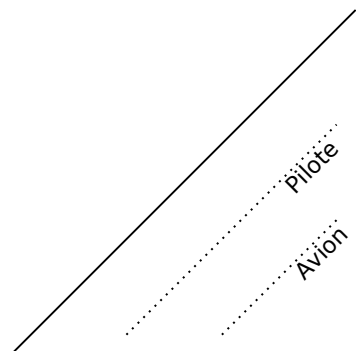

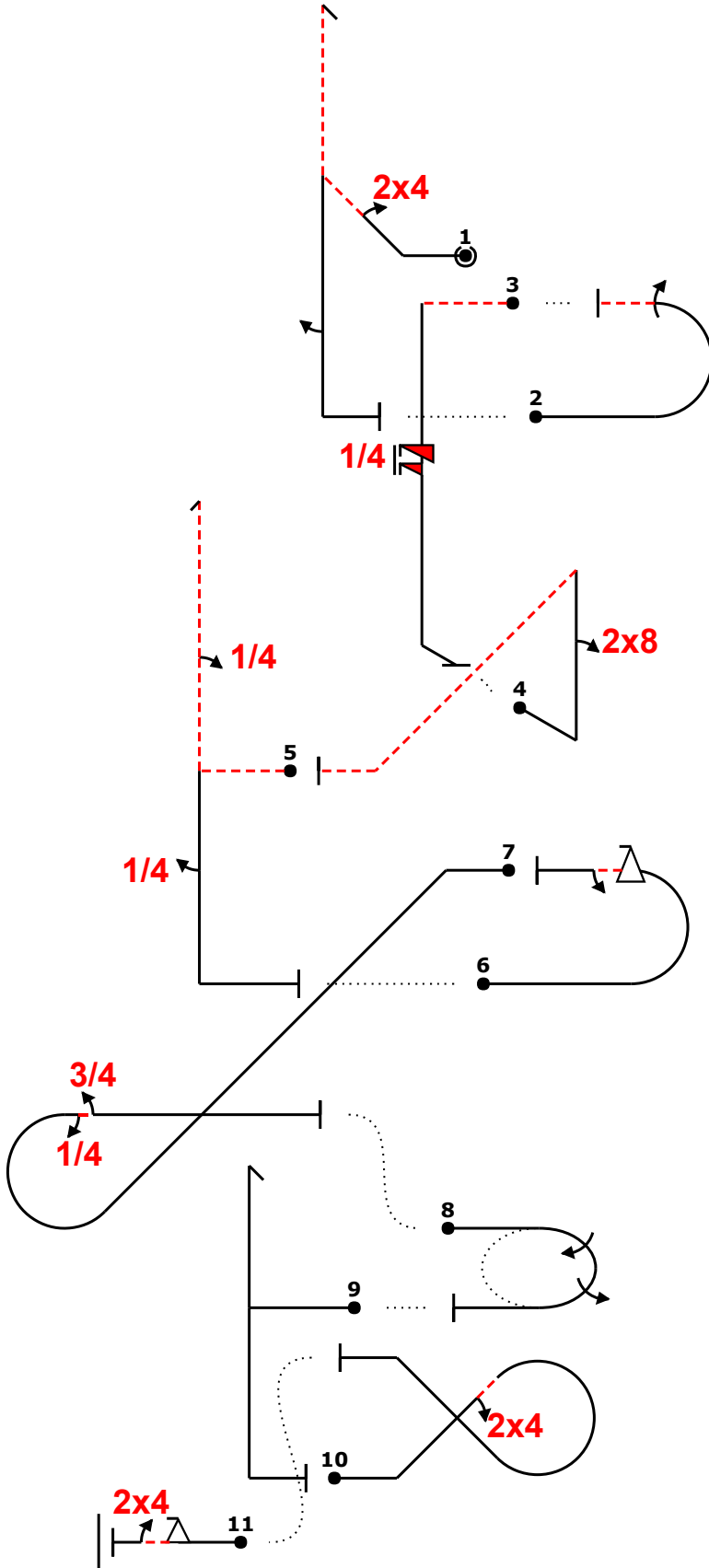

Avion			
Fig 1	5.3.2.1 9.4.2.2 9.1.5.2	24 7 4	35
Fig 2	7.2.1.1 9.1.3.4	6 8	14
Fig 3	1.1.7.4 9.12.1.5	9 6	15
Fig 4	1.2.5.1 9.8.1.1	14 7	21
Fig 5	5.2.1.4 9.1.1.1 9.1.5.1	22 6 2	30
Fig 6	7.2.2.1 9.9.3.4 9.1.3.2	6 11 4	21
Fig 7	8.5.3.3 9.1.3.1 9.1.3.3	10 2 6	18
Fig 8	2.2.6.1	15	15
Fig 9	5.2.1.1	17	17
Fig 10	7.3.2.1 9.4.2.2	14 7	21
Fig 11	1.1.1.1 9.9.3.2 9.4.3.2	2 11 5	18
Total K = 225 (max K = 225)			

Le K Aresti normal de la figure 8 a été changé selon le règlement 2017 france national_2 connu

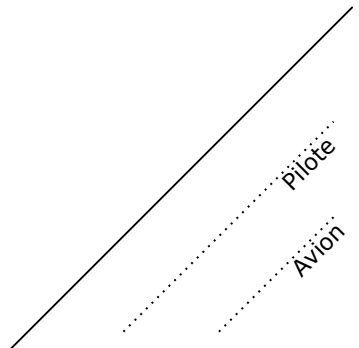



Figure K
225
K total
245

Nom des Juges		Vol N°
Signature	Numéro	

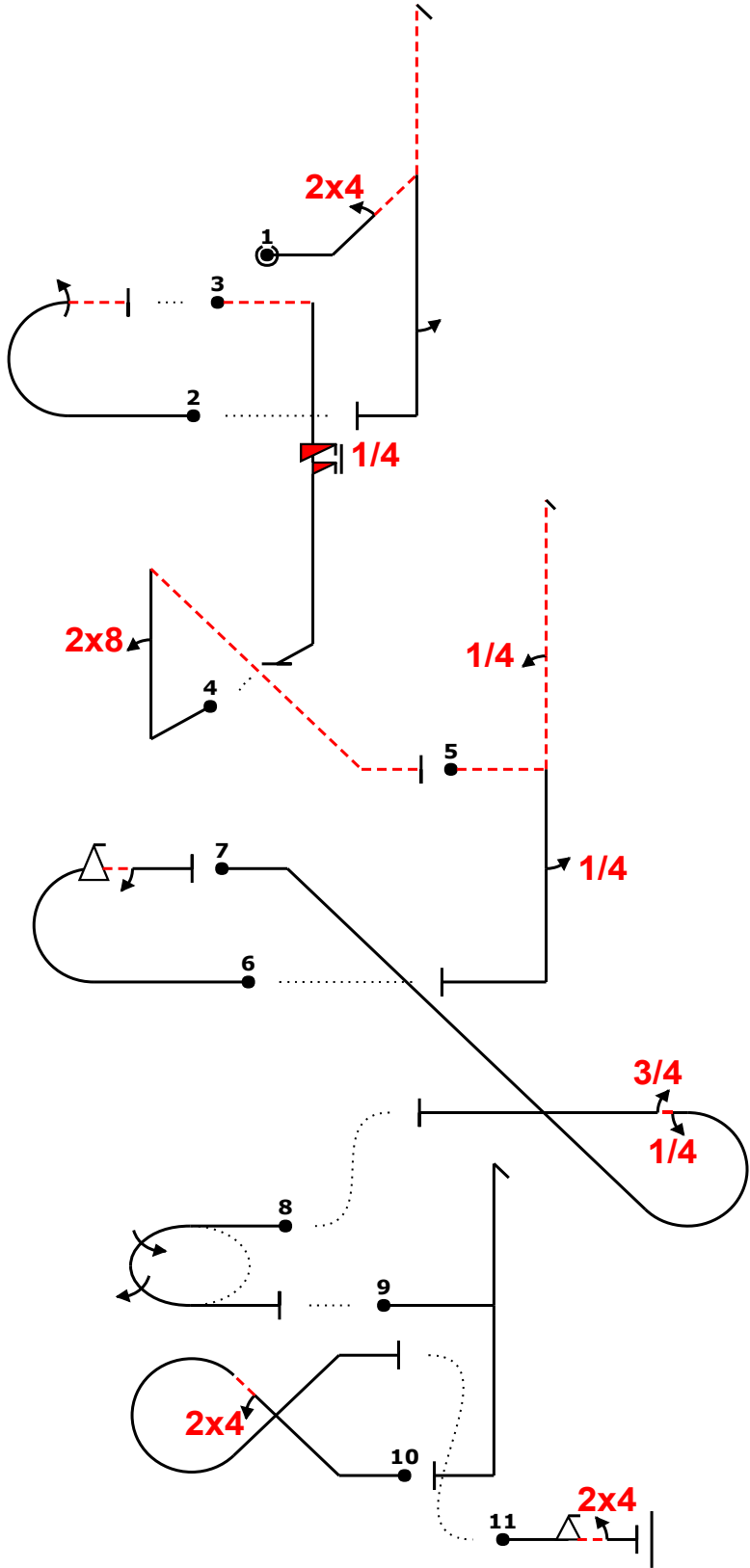

Fig	Pos	Remarks	Grade
1			.
2			.
3			.
4			.
5			.
6			.
7			.
8			.
9			.
10			.
11			.

Cadre(Coef)	.
20	.

Trop Bas		Echauf. non OK	
Trop Haut		Battem. d'Ailes	
Interruptions		Disqualifié	
Insertions		Autre(noter...)	

Le K Aresti normal de la figure 8 a été changé selon le règlement 2017 france national_2 connu
 Vérification :11-12-2017 11:01 OpenAero 2018.1.1 2017 france national_2 connu Le programme est correct
 24dh(.).. '2.' (-7,0) .'m1- (2,0) ~-iv..Sis..' (-1,1) ~'8'k.'-> ~-.'4..'h.4..+ (-9,0) ..mf,2''irc'
 4,3~ (-5,8) 2jio2 (3,0) +'h.. 24g (a□□3,13) 2f;24+

Fig 1	K	Fig 2	K	Fig 3	K	Fig 4	K	Fig 5	K	Fig 6	K	Fig 7	K	Fig 8	K	Fig 9	K	Fig 10	K	Fig 11	K
5.3.2.1	24	7.2.1.1	6	1.1.7.4	9	1.2.5.1	14	5.2.1.4	22	7.2.2.1	6	8.5.3.3	10	2.2.6.1	15	5.2.1.1	17	7.3.2.1	14	1.1.1.1	2
9.4.2.2	7	9.1.3.4	8	9.12.1.5	6	9.8.1.1	7	9.1.1.1	6	9.9.3.4	11	9.1.3.1	2					9.4.2.2	7	9.9.3.2	11
9.1.5.2	4							9.1.5.1	2	9.1.3.2	4	9.1.3.3	6							9.4.3.2	5
SF 5	35	SF 7	14	SF 3	15	SF 7	21	SF 5	30	SF 4	21	SF 7	18	SF 2	15	SF 5	17	SF 7	21	SF 4	18

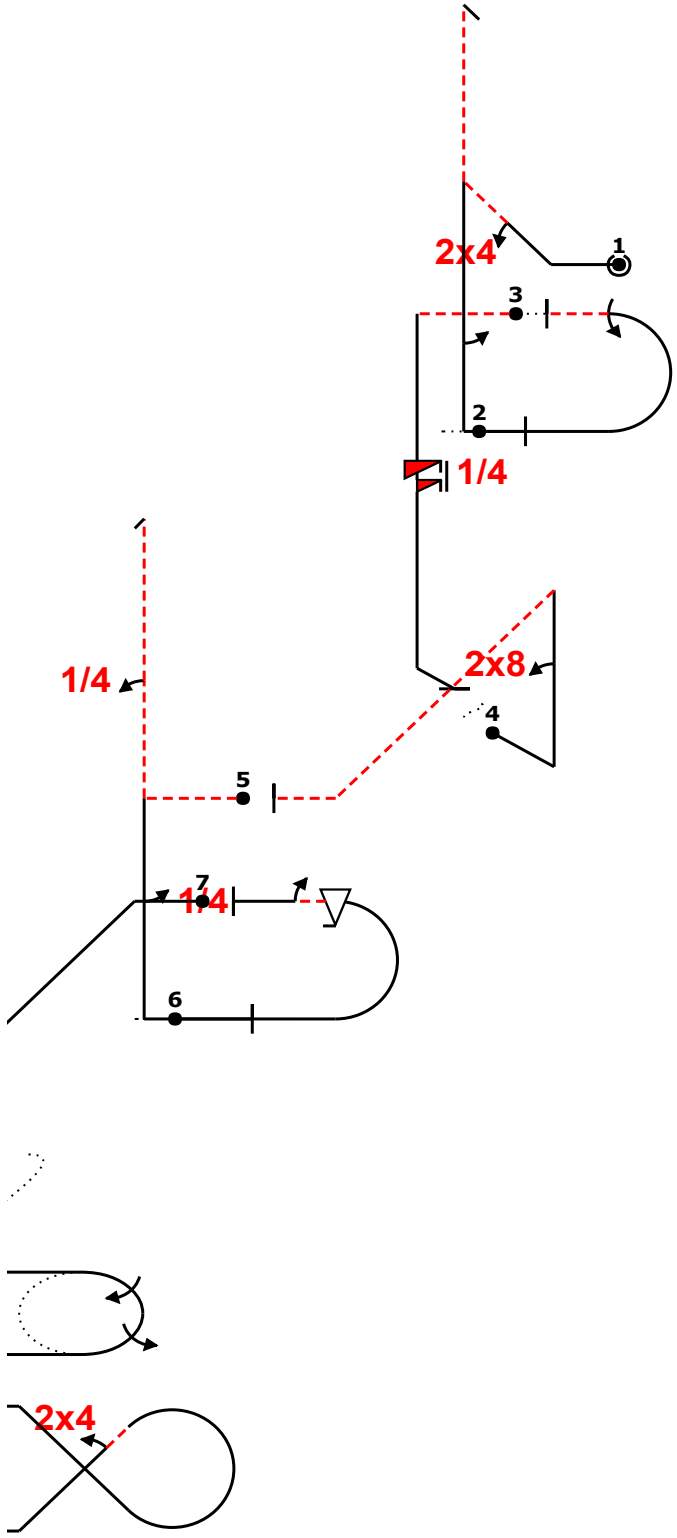

Fig	Pos	Remarks	Grade
1			.
2			.
3			.
4			.
5			.
6			.
7			.
8			.
9			.
10			.
11			.

Cadre(Coef)	.
20	.

Trop Bas		Echauf. non OK	
Trop Haut		Battem. d'Ailes	
Interruptions		Disqualifié	
Insertions		Autre(noter...)	

Le K Aresti normal de la figure 8 a été changé selon le règlement 2017 france national_2 connu
 Vérification :11-12-2017 11:01 OpenAero 2018.1.1 2017 france national_2 connu Le programme est correct
 24dh(.).. '2.' (-7,0) . 'm1- (2,0) ~-iv..5is..' (-1,1) ~'8'k.'-> ~-.'4..'h.4..+ (-9,0) ..mf,2 ''irc'
 4,3~ (-5,8) 2jio2 (3,0) +'h.. 24g (â□□3,13) 2f;24+

Fig 1	K	Fig 2	K	Fig 3	K	Fig 4	K	Fig 5	K	Fig 6	K	Fig 7	K	Fig 8	K	Fig 9	K	Fig 10	K	Fig 11	K
5.3.2.1	24	7.2.1.1	6	1.1.7.4	9	1.2.5.1	14	5.2.1.4	22	7.2.2.1	6	8.5.3.3	10	2.2.6.1	15	5.2.1.1	17	7.3.2.1	14	1.1.1.1	2
9.4.2.2	7	9.1.3.4	8	9.12.1.5	6	9.8.1.1	7	9.1.1.1	6	9.9.3.4	11	9.1.3.1	2					9.4.2.2	7	9.9.3.2	11
9.1.5.2	4							9.1.5.1	2	9.1.3.2	4	9.1.3.3	6					9.4.3.2	5		
SF 5	35	SF 7	14	SF 3	15	SF 7	21	SF 5	30	SF 4	21	SF 7	18	SF 2	15	SF 5	17	SF 7	21	SF 4	18