



Connu N°1 2019		Form A
Pilote ID	France Doret/excellence connu	
		Vol N°

No	Symbol	Cat. No.	K	Total K	Grade	Pos	Remarks	Item	K	Grade
1		8.6.2.1 9.9.1.3 9.8.3.1 9.1.3.3	12 15 3 6	36				Pos.	35	
								Harm.	0	
2		8.4.13.2 9.1.2.4 9.9.4.2 9.4.4.2	13 10 11 5	39				Fig K	Total K	
								320	355	
<b>Penalties</b>										
3		6.2.1.1 9.8.1.2 9.1.5.4	15 11 8	34				Trop Bas		
								Trop Haut		
								Interruptions		
								Insertions		
4		1.1.6.1 9.4.1.2 9.1.1.2	10 9 8	27				Echauf. non OK		
								Battem. d'Ailes		
								Disqualifié		
								Autre(noter...)		
<b>Final Freestyle</b>										
5		8.6.4.3 9.11.1.5 9.10.8.4 9.1.3.2	13 4 15 4	36				Duration	Min	Sec
6		2.3.5.3	36	36				Signature		
								Name		
								Number		
7		1.3.11.1 9.10.4.2 9.1.1.4	20 13 12	45						
8		8.4.15.4 9.8.4.2 9.2.2.4	13 7 11	31						
9		7.2.3.4 9.1.3.6 9.1.3.3 9.1.3.7	9 10 6 11	36						

/-----/ Pilote  
 /-----/ Avion



Connu N°1 2019		Form B
Pilote ID	France Doret/excellence connu	
	Vol N°	

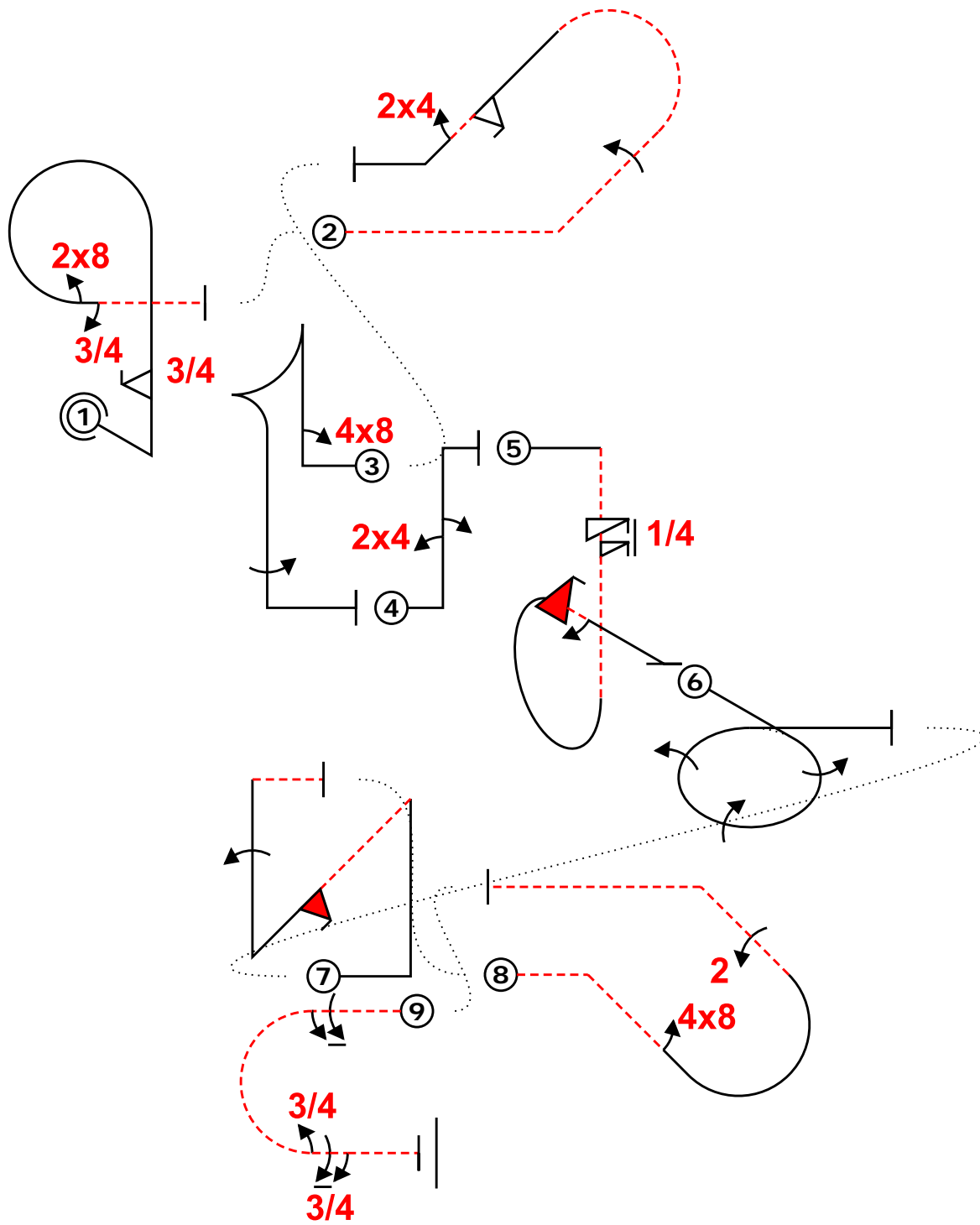

Avion			
Fig	Aresti	K	
1	8.6.2.1	12	36
	9.9.1.3	15	
	9.8.3.1	3	
	9.1.3.3	6	
2	8.4.13.2	13	39
	9.1.2.4	10	
	9.9.4.2	11	
	9.4.4.2	5	
3	6.2.1.1	15	34
	9.8.1.2	11	
	9.1.5.4	8	
4	1.1.6.1	10	27
	9.4.1.2	9	
	9.1.1.2	8	
5	8.6.4.3	13	36
	9.11.1.5	4	
	9.10.8.4	15	
	9.1.3.2	4	
6	2.3.5.3	36	36
7	1.3.11.1	20	45
	9.10.4.2	13	
	9.1.1.4	12	
8	8.4.15.4	13	31
	9.8.4.2	7	
	9.2.2.4	11	
9	7.2.3.4	9	36
	9.1.3.6	10	
	9.1.3.3	6	
	9.1.3.7	11	
<b>Total K = 320</b>		<b>(max K = 350)</b>	

Vérification :15-1-2019 12:12 OpenAero 2019.1.4 2018 france doret/excellence connu Le programme est correct  
 ej /~|\*3frp8,3- (3,-4) -ldb2f,24 (5,17) ~~~~~+,48tal+~~~~~+v24,2+~~ 5sirp\*|\*if,2~ 3joi3> (-36,14) n(2if)1- (6,11) -48irdb~~22''-  
 (0,7) -6a3,7-

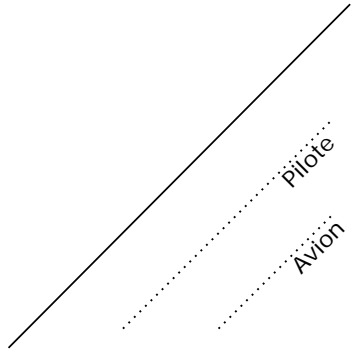



Connu N°1 2019		Form C
Pilote ID	France Doret/excellence connu	Vol N°

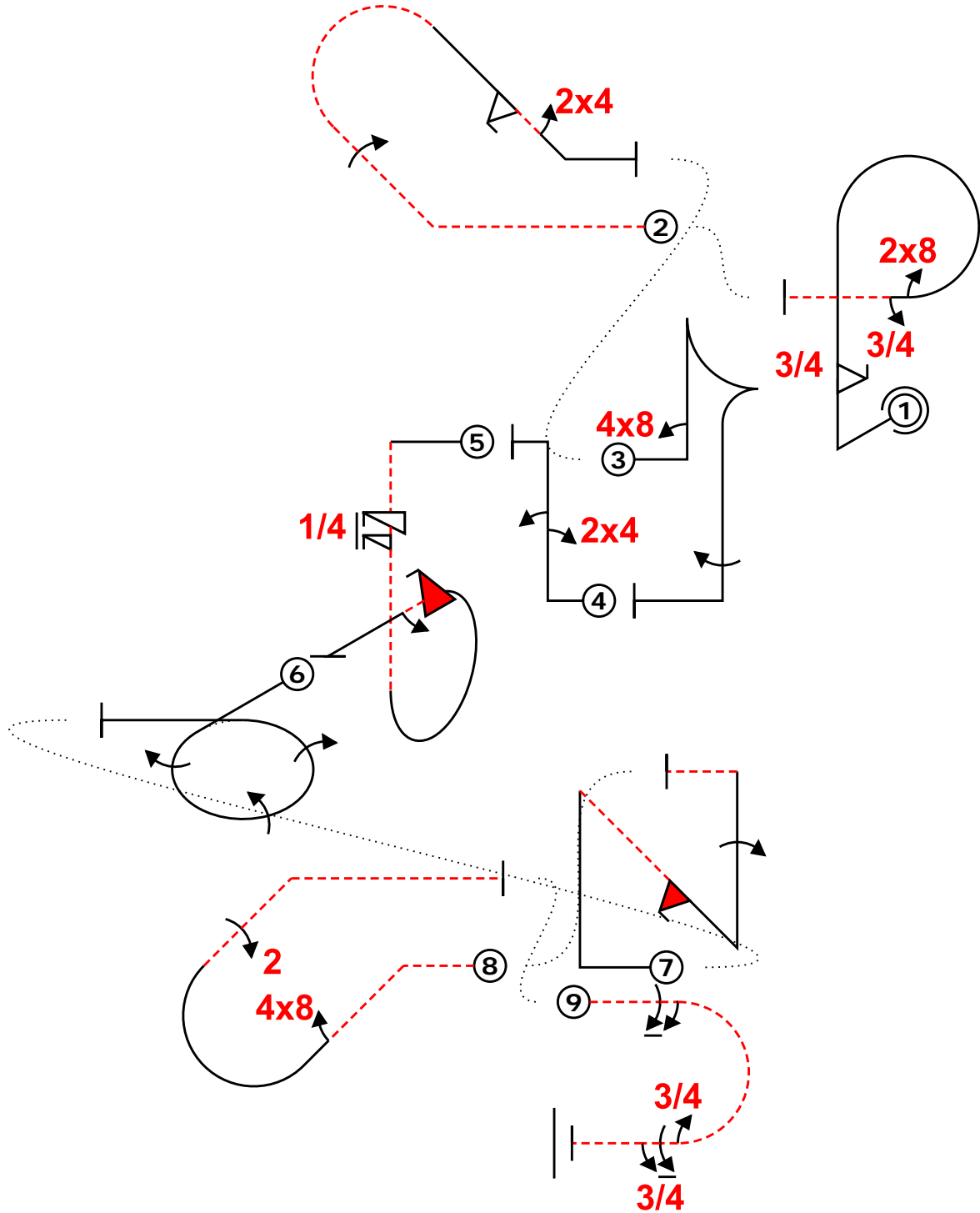

Avion			
Fig	Aresti	K	
1	8.6.2.1	12	36
	9.9.1.3	15	
	9.8.3.1	3	
	9.1.3.3	6	
2	8.4.13.2	13	39
	9.1.2.4	10	
	9.9.4.2	11	
	9.4.4.2	5	
3	6.2.1.1	15	34
	9.8.1.2	11	
	9.1.5.4	8	
4	1.1.6.1	10	27
	9.4.1.2	9	
	9.1.1.2	8	
5	8.6.4.3	13	36
	9.11.1.5	4	
	9.10.8.4	15	
	9.1.3.2	4	
6	2.3.5.3	36	36
7	1.3.11.1	20	45
	9.10.4.2	13	
	9.1.1.4	12	
8	8.4.15.4	13	31
	9.8.4.2	7	
	9.2.2.4	11	
9	7.2.3.4	9	36
	9.1.3.6	10	
	9.1.3.3	6	
	9.1.3.7	11	
<b>Total K = 320</b>		<b>(max K = 350)</b>	

Vérification :15-1-2019 12:12 OpenAero 2019.1.4 2018 france doret/excellence connu Le programme est correct  
 ej /~|"3frp8,3- (3,-4) -ldb2f,24 (5,17) ~~~~~+,48tal+~~~~~+v24,2+~~ 5sirp|"\*if,2~ 3joi3> (-36,14) n(2if)1- (6,11) -48irdb~~~22"-  
 (0,7) -6a3,7-

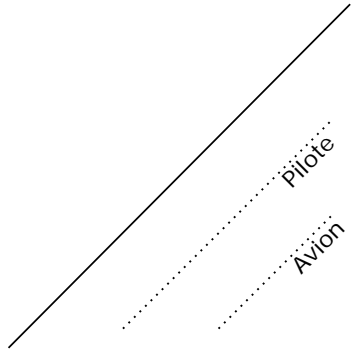



France	Doret/excellence	2019
connu		Connu N° 1



Figure K  
320  
K total  
355

Nom des Juges		Vol N°
Signature	Numéro	

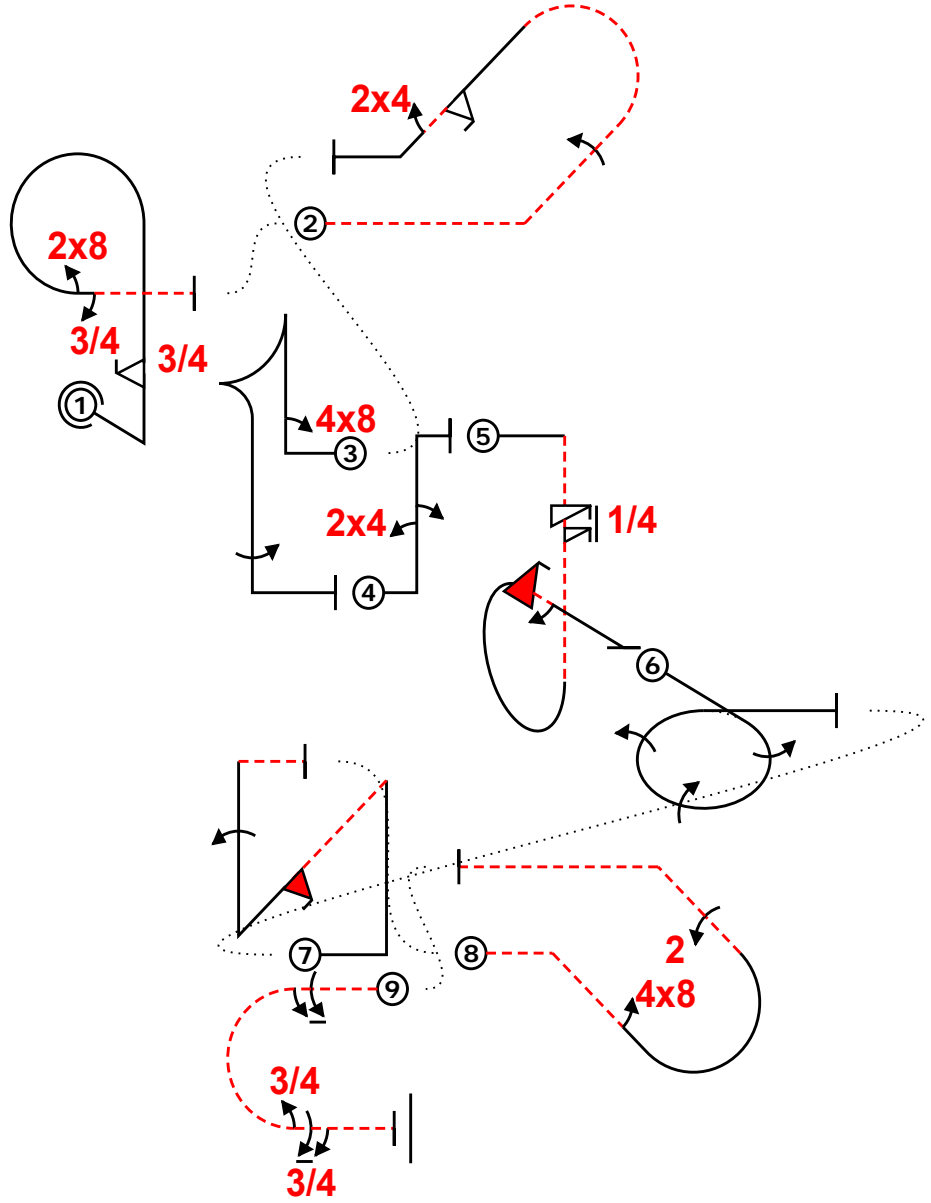

Fig	Grade	Pos	Remarks
1	.		
2	.		
3	.		
4	.		
5	.		
6	.		
7	.		
8	.		
9	.		

Cadre(Coef)	35	.
-------------	----	---

Trop Bas		Echauf. non OK	
Trop Haut		Battem. d'Ailes	
Interruptions		Disqualifié	
Insertions		Autre(noter...)	

Vérification :15-1-2019 12:12 OpenAero 2019.1.4 2018 france doret/excellence connu Le programme est le respect

Fig 1	K	Fig 2	K	Fig 3	K	Fig 4	K	Fig 5	K	Fig 6	K	Fig 7	K	Fig 8	K	Fig 9	K
8.6.2.1	12	8.4.13.2	13	6.2.1.1	15	1.1.6.1	10	8.6.4.3	13	2.3.5.3	36	1.3.11.1	20	8.4.15.4	13	7.2.3.4	9
9.9.1.3	15	9.1.2.4	10	9.8.1.2	11	9.4.1.2	9	9.11.1.5	4			9.10.4.2	13	9.8.4.2	7	9.1.3.6	10
9.8.3.1	3	9.9.4.2	11	9.1.5.4	8	9.1.1.2	8	9.10.8.4	15			9.1.1.4	12	9.2.2.4	11	9.1.3.3	6
9.1.3.3	6	9.4.4.2	5					9.1.3.2	4							9.1.3.7	11
	<b>36</b>		<b>39</b>		<b>34</b>		<b>27</b>		<b>36</b>		<b>36</b>		<b>45</b>		<b>31</b>		<b>36</b>

Pilote:

Avion:

Equipe: FRA



France	Doret/excellence	2019
connu	Connu N° 1	

Figure K  
320  
K total  
355

Nom des Juges	
Signature	Numéro

Vol N°
--------

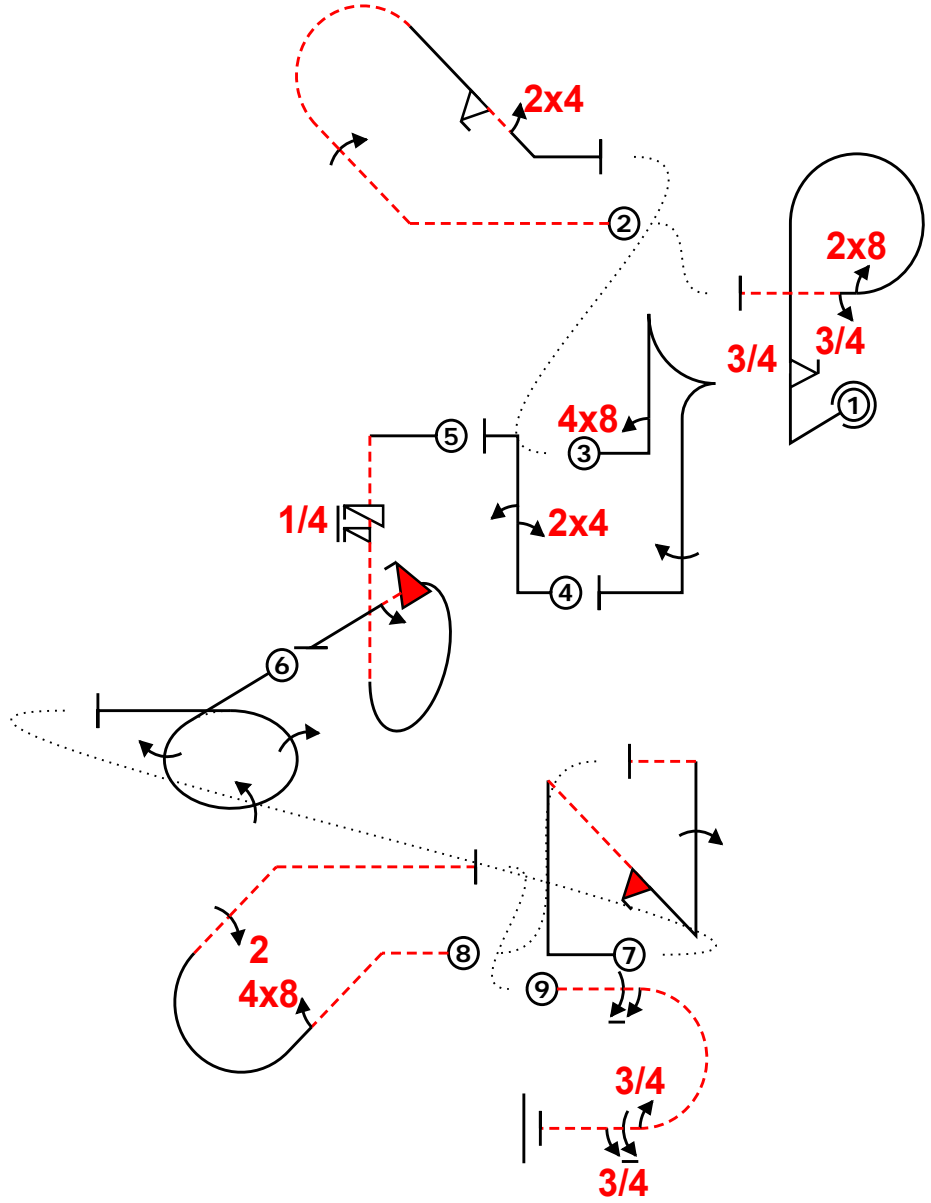

Fig	Grade	Pos	Remarks
1	.		
2	.		
3	.		
4	.		
5	.		
6	.		
7	.		
8	.		
9	.		

Cadre(Coef)	35	.
-------------	----	---

Trop Bas		Echauf. non OK	
Trop Haut		Battem. d'Ailes	
Interruptions		Disqualifié	
Insertions		Autre(noter...)	

Vérification :15-1-2019 12:12 OpenAero 2019.1.4 2018 france doret/excellence connu Le programme est le respect

Fig 1	K	Fig 2	K	Fig 3	K	Fig 4	K	Fig 5	K	Fig 6	K	Fig 7	K	Fig 8	K	Fig 9	K
8.6.2.1	12	8.4.13.2	13	6.2.1.1	15	1.1.6.1	10	8.6.4.3	13	2.3.5.3	36	1.3.11.1	20	8.4.15.4	13	7.2.3.4	9
9.9.1.3	15	9.1.2.4	10	9.8.1.2	11	9.4.1.2	9	9.11.1.5	4			9.10.4.2	13	9.8.4.2	7	9.1.3.6	10
9.8.3.1	3	9.9.4.2	11	9.1.5.4	8	9.1.1.2	8	9.10.8.4	15			9.1.1.4	12	9.2.2.4	11	9.1.3.3	6
9.1.3.3	6	9.4.4.2	5					9.1.3.2	4							9.1.3.7	11
	<b>36</b>		<b>39</b>		<b>34</b>		<b>27</b>		<b>36</b>		<b>36</b>		<b>45</b>		<b>31</b>		<b>36</b>

Pilote:

Avion:

Equipe: FRA

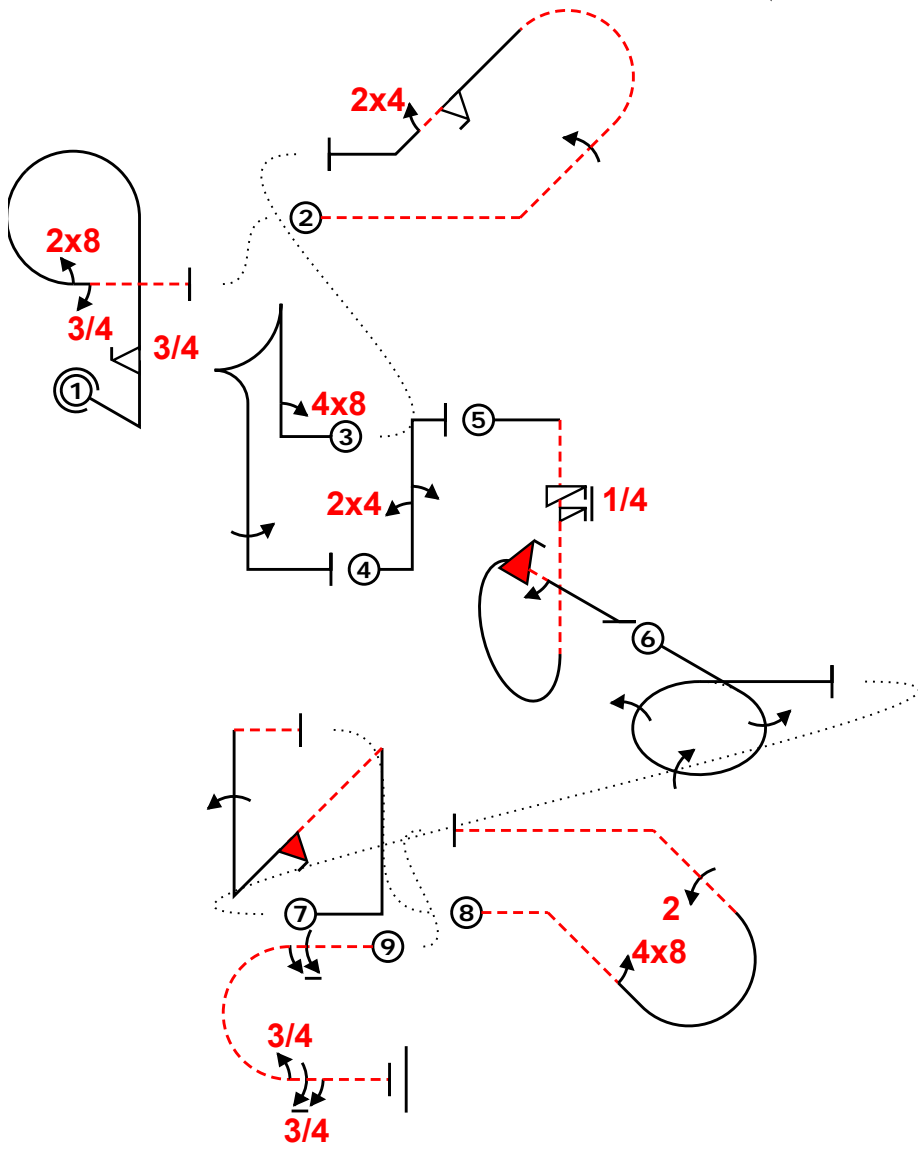



CONNU N°2 2019

Form A

Pilote ID

France Doret/excellence connu

Vol N°

No	Symbol	Cat. No.	K	Total K	Grade	Pos	Remarks	Item	K	Grade
1		8.4.17.3 9.9.4.4 9.2.2.4	11 11 11	33	.			Pos.	35	
								Harm.	0	
2		1.2.7.4 9.12.1.4 9.1.5.1 9.4.2.2	14 7 2 7	30	.			Fig K	Total K	
								326	361	
<b>Penalties</b>										
3		7.2.3.4 9.1.3.6 9.1.3.7 9.1.3.3	9 10 11 6	36	.			Trop Bas		
								Trop Haut		
								Interruptions		
								Insertions		
4		6.2.1.4 9.8.1.1 9.1.5.3	17 7 6	30	.			Echauf. non OK		
								Battem. d'Ailes		
								Disqualifié		
								Autre(noter...)		
<b>Final Freestyle</b>										
5		8.8.1.1 9.1.1.3 9.2.5.4 9.1.1.1	18 10 9 6	43	.			Duration	Min	Sec
<b>Judges Details</b>										
6		1.3.4.4 9.4.4.2 9.10.4.6	18 5 16	39	.			Signature		
								Name		
								Number		
7		8.6.3.1 9.10.6.4 9.8.3.2 9.1.3.2	15 19 7 4	45	.					
8		2.3.2.2	34	34	.					
9		5.2.1.1 9.1.1.2 9.9.5.3	17 8 11	36	.					

\_\_\_\_\_  
 ..... Pilote  
 ..... Avion



CONNU N°2 2019		Form B
Pilote ID	France Doret/excellence connu	Vol N°

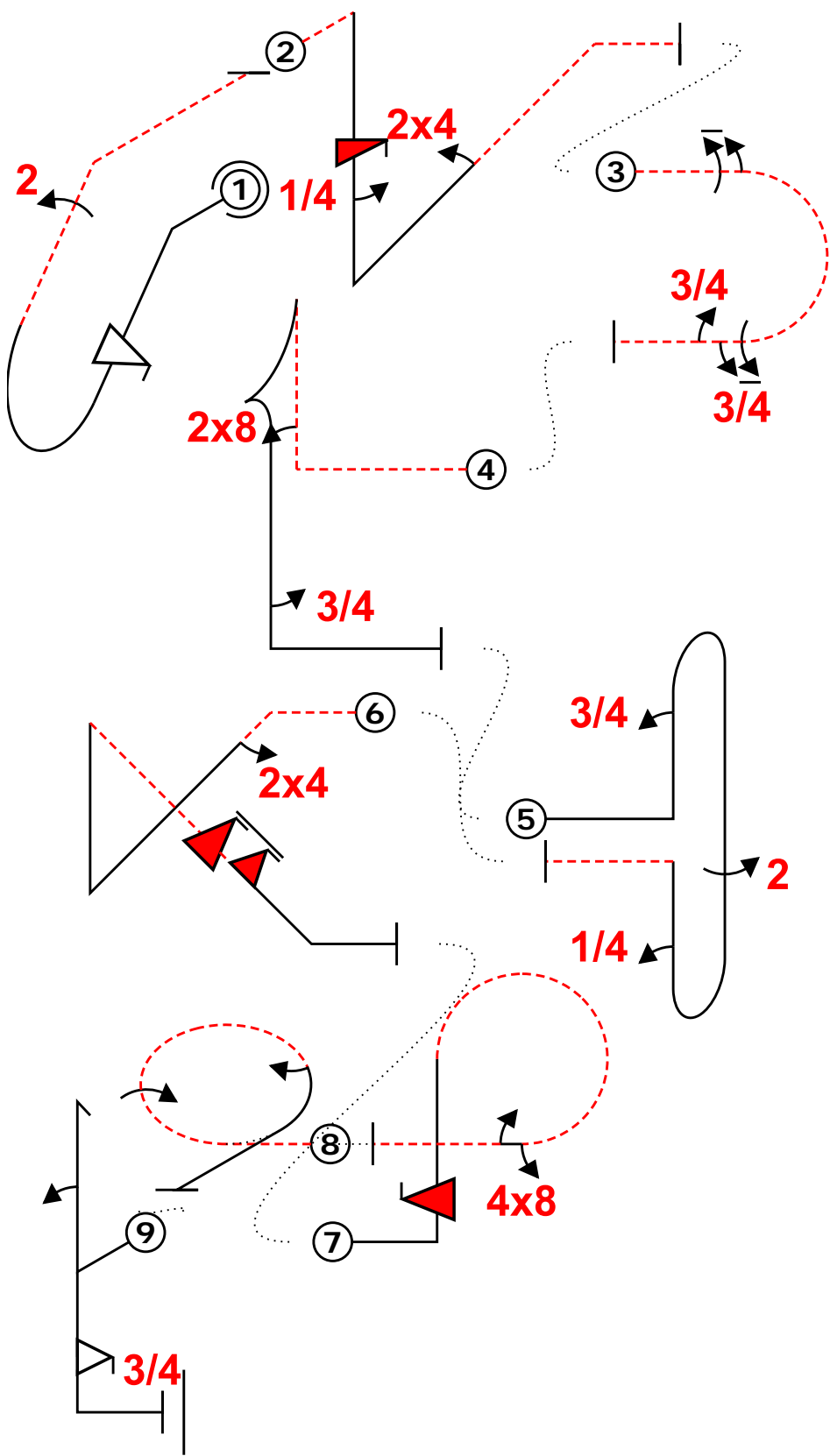

Avion			
Fig	Aresti	K	
1	8.4.17.3	11	33
	9.9.4.4	11	
	9.2.2.4	11	
2	1.2.7.4	14	30
	9.12.1.4	7	
	9.1.5.1	2	
	9.4.2.2	7	
3	7.2.3.4	9	36
	9.1.3.6	10	
	9.1.3.7	11	
	9.1.3.3	6	
4	6.2.1.4	17	30
	9.8.1.1	7	
	9.1.5.3	6	
5	8.8.1.1	18	43
	9.1.1.3	10	
	9.2.5.4	9	
	9.1.1.1	6	
6	1.3.4.4	18	39
	9.4.4.2	5	
	9.10.4.6	16	
7	8.6.3.1	15	45
	9.10.6.4	19	
	9.8.3.2	7	
	9.1.3.2	4	
8	2.3.2.2	34	34
9	5.2.1.1	17	36
	9.1.1.2	8	
	9.9.5.3	11	
<b>Total K = 326</b> (max K = 350)			

Vérification :15-1-2019 12:14 OpenAero 2019.1.4 2018 france doret/excellence connu Le programme est correct  
 ej firdb22- is:\*|\*4ik24- (-7,6) -6a7,3- (-2,6) -8ta3 (0,8) 3bb(22)4- (-4,-7) -24iw6if (-7,14) ifrp48,2- (2,0) \*\*\*\*\*3j15 (2,0) 2h3f

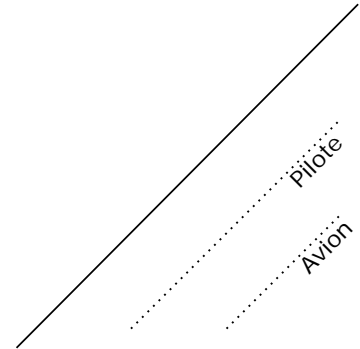





CONNU N°2 2019		Form C
Pilote ID	France Doret/excellence connu	Vol N°

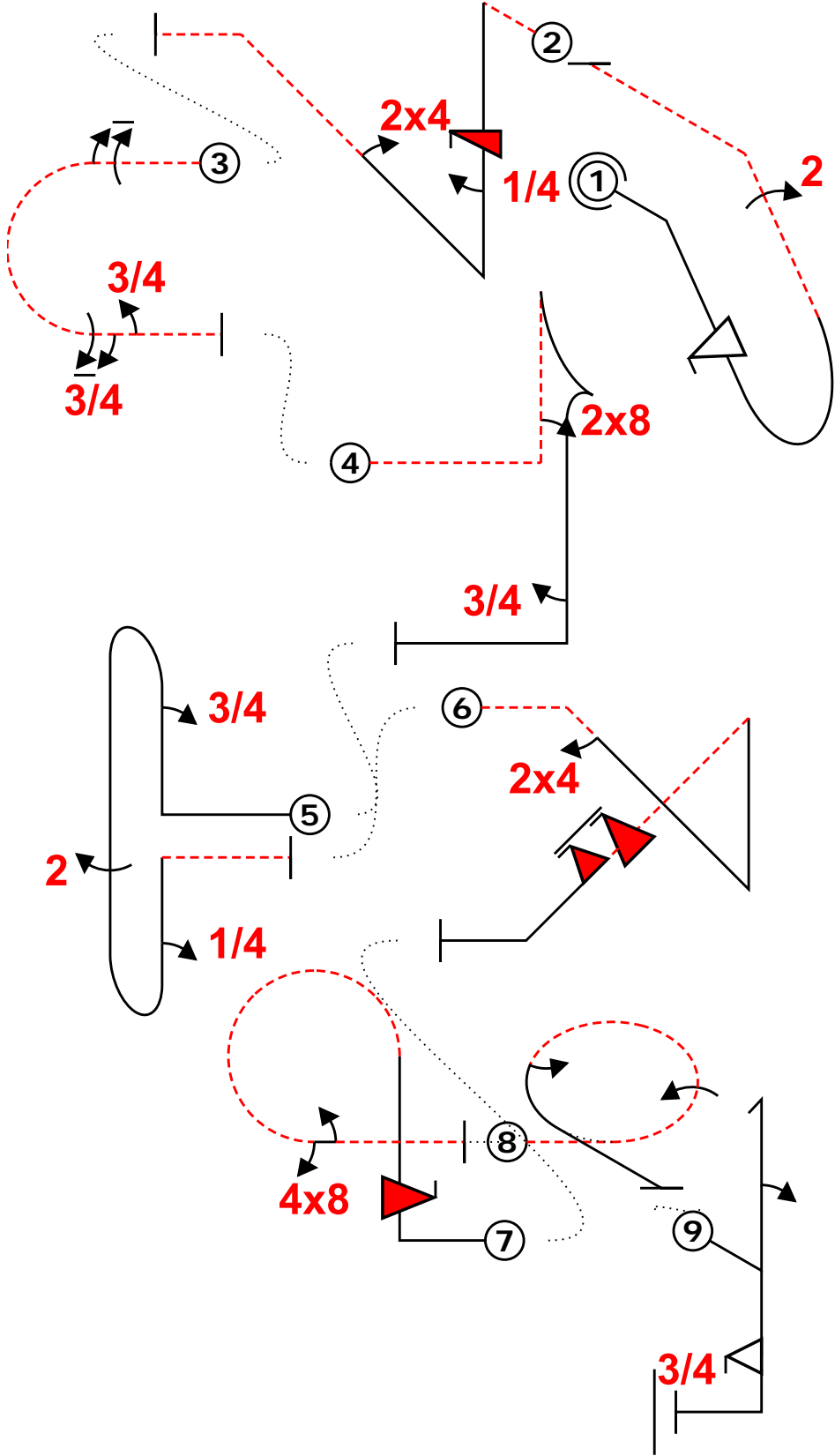

Avion			
Fig	Aresti	K	
1	8.4.17.3	11	33
	9.9.4.4	11	
	9.2.2.4	11	
2	1.2.7.4	14	30
	9.12.1.4	7	
	9.1.5.1	2	
	9.4.2.2	7	
3	7.2.3.4	9	36
	9.1.3.6	10	
	9.1.3.7	11	
	9.1.3.3	6	
4	6.2.1.4	17	30
	9.8.1.1	7	
	9.1.5.3	6	
5	8.8.1.1	18	43
	9.1.1.3	10	
	9.2.5.4	9	
	9.1.1.1	6	
6	1.3.4.4	18	39
	9.4.4.2	5	
	9.10.4.6	16	
7	8.6.3.1	15	45
	9.10.6.4	19	
	9.8.3.2	7	
	9.1.3.2	4	
8	2.3.2.2	34	34
9	5.2.1.1	17	36
	9.1.1.2	8	
	9.9.5.3	11	
<b>Total K = 326</b> (max K = 350)			

Vérification :15-1-2019 12:14 OpenAero 2019.1.4 2018 france doret/excellence connu Le programme est correct  
 ej firdb22- -is:\*|\*4ik24- (-7,6) -6a7,3- (-2,6) -8ta3 (0,8) 3bb(22)4- (-4,-7) -24iw6if (-7,14) ifrp48,2- (2,0) \*\*\*\*\*3j15 (2,0) 2h3f

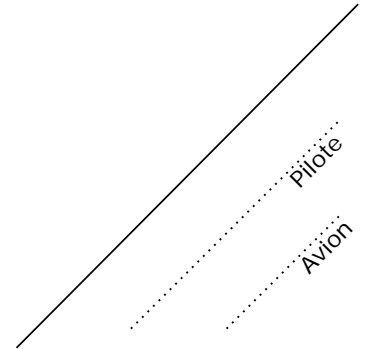



France	Doret/excellence	2019
connu	CONNU N°2	



Figure K  
326  
K total  
361

Nom des Juges		Vol N°
Signature	Numéro	

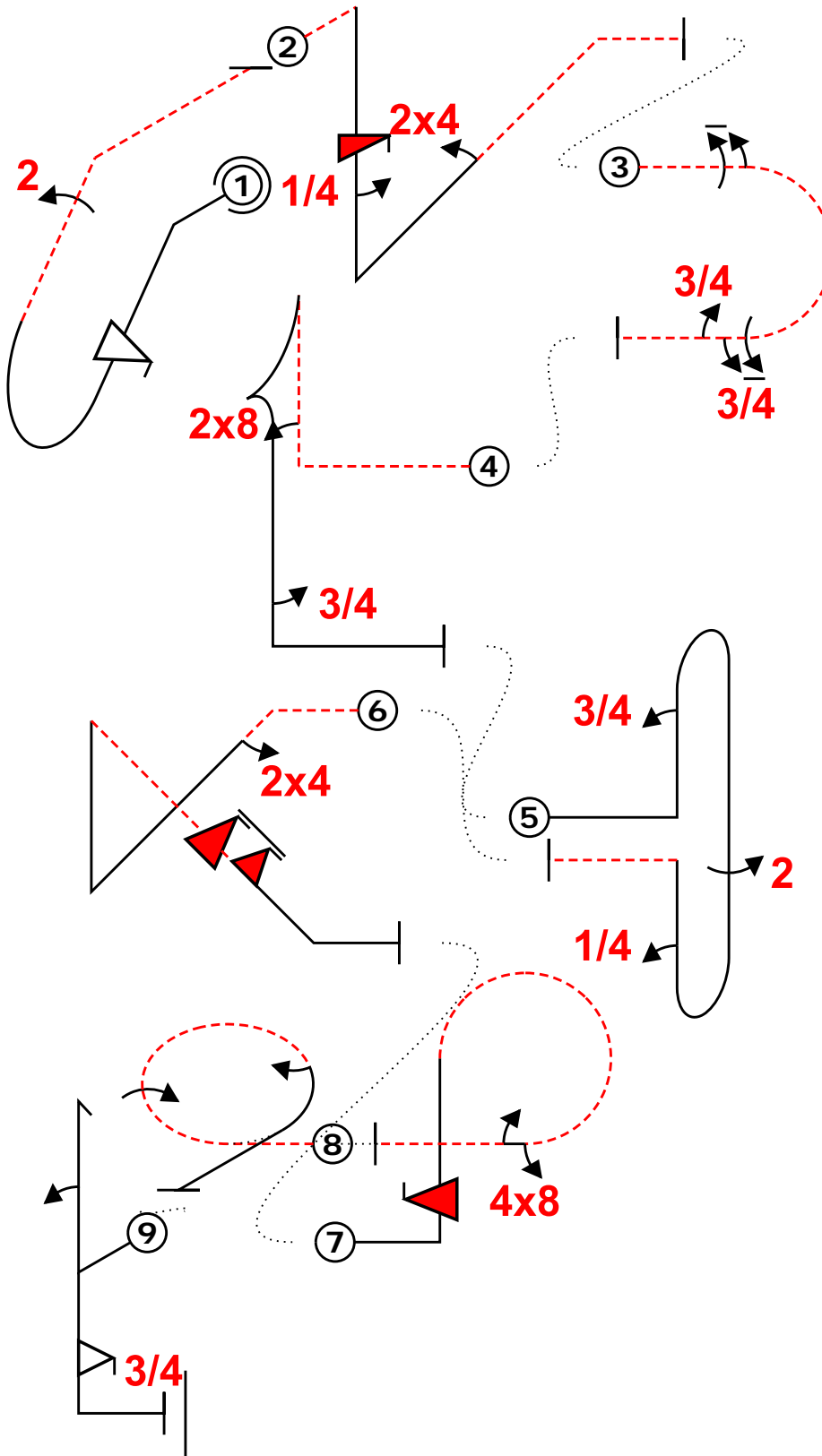

Fig	Grade	Pos	Remarks
1	.		
2	.		
3	.		
4	.		
5	.		
6	.		
7	.		
8	.		
9	.		

Cadre(Coef)	.
35	.

Trop Bas		Echauf. non OK	
Trop Haut		Battem. d'Ailes	
Interruptions		Disqualifié	
Insertions		Autre(noter...)	

Vérification :15-1-2019 12:14 OpenAero 2019.1.4 2018 france doret/excellence connu Le programme est le suivant  
ej firdb22- -is:\*"4ik24- (-7,6) -6a7,3- (-2,6) -8ta3 (0,8) 3bb(22)4- (-4,-7) -24iw6if (-7,14) ifrp48,2- (2,0) ""-3jl5 (2,0) 2h3f

Fig 1	K	Fig 2	K	Fig 3	K	Fig 4	K	Fig 5	K	Fig 6	K	Fig 7	K	Fig 8	K	Fig 9	K
8.4.17.3	11	1.2.7.4	14	7.2.3.4	9	6.2.1.4	17	8.8.1.1	18	1.3.4.4	18	8.6.3.1	15	2.3.2.2	34	5.2.1.1	17
9.9.4.4	11	9.12.1.4	7	9.1.3.6	10	9.8.1.1	7	9.1.1.3	10	9.4.4.2	5	9.10.6.4	19			9.1.1.2	8
9.2.2.4	11	9.1.5.1	2	9.1.3.7	11	9.1.5.3	6	9.2.5.4	9	9.10.4.6	16	9.8.3.2	7			9.9.5.3	11
		9.4.2.2	7	9.1.3.3	6			9.1.1.1	6			9.1.3.2	4				
	<b>33</b>		<b>30</b>		<b>36</b>		<b>30</b>		<b>43</b>		<b>39</b>		<b>45</b>		<b>34</b>		<b>36</b>

Pilote:

Avion:

Equipe: FRA



France	Doret/excellence	2019
connu	CONNU N°2	

Figure K  
326  
K total  
361

Nom des Juges		Vol N°
Signature	Numéro	

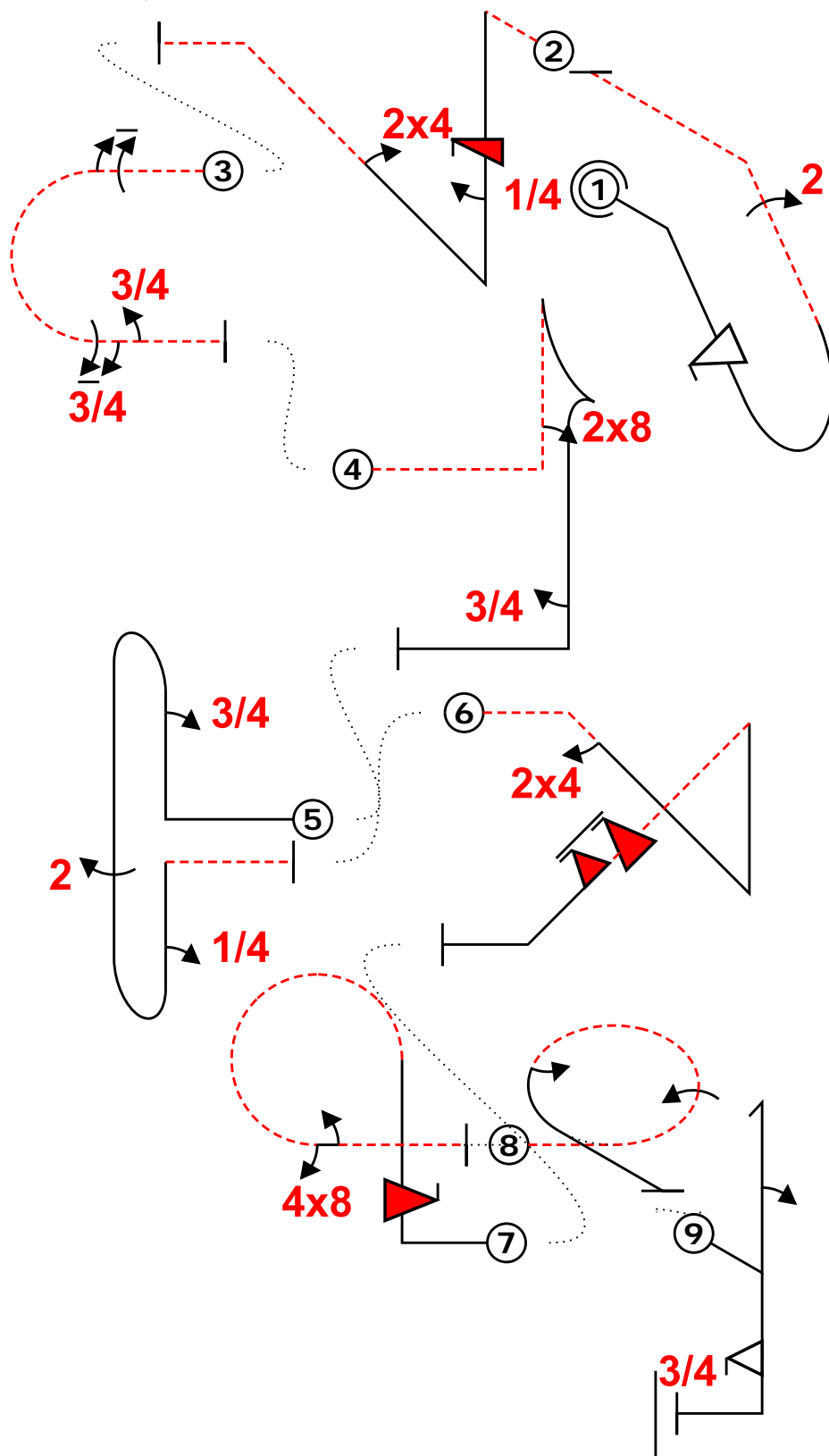

Fig	Grade	Pos	Remarks
1	.		
2	.		
3	.		
4	.		
5	.		
6	.		
7	.		
8	.		
9	.		

Cadre(Coef)	35	.
-------------	----	---

Trop Bas		Echauf. non OK	
Trop Haut		Battem. d'Ailes	
Interruptions		Disqualifié	
Insertions		Autre(noter...)	

Vérification :15-1-2019 12:14 OpenAero 2019.1.4 2018 france doret/excellence connu Le programme est le suivant  
ej firdb22- -is:\*4ik24- (-7,6) -6a7,3- (-2,6) -8ta3 (0,8) 3bb(22)4- (-4,-7) -24iw6if (-7,14) ifrp48,2- (2,0) -3jl5 (2,0) 2h3f

Fig 1	K	Fig 2	K	Fig 3	K	Fig 4	K	Fig 5	K	Fig 6	K	Fig 7	K	Fig 8	K	Fig 9	K
8.4.17.3	11	1.2.7.4	14	7.2.3.4	9	6.2.1.4	17	8.8.1.1	18	1.3.4.4	18	8.6.3.1	15	2.3.2.2	34	5.2.1.1	17
9.9.4.4	11	9.12.1.4	7	9.1.3.6	10	9.8.1.1	7	9.1.1.3	10	9.4.4.2	5	9.10.6.4	19			9.1.1.2	8
9.2.2.4	11	9.1.5.1	2	9.1.3.7	11	9.1.5.3	6	9.2.5.4	9	9.10.4.6	16	9.8.3.2	7			9.9.5.3	11
		9.4.2.2	7	9.1.3.3	6			9.1.1.1	6			9.1.3.2	4				
	<b>33</b>		<b>30</b>		<b>36</b>		<b>30</b>		<b>43</b>		<b>39</b>		<b>45</b>		<b>34</b>		<b>36</b>

Pilote:

Avion:

Equipe: FRA

